

DESIGN NOTES

A Precision Wideband Current Probe for LCD Backlight Measurement – Design Note 101

Jim Williams

Evaluation and optimization of Cold Cathode Fluorescent Lamp (CCFL) performance requires highly accurate AC current measurement. CCFLs, used to backlight LCD displays, typically operate at 30kHz to 70kHz with measurable harmonic content into the low MHz region¹. Accurate determination of RMS operating current is important for electrical and emissivity efficiency computations and to ensure long lamp life. Additionally, it is desirable to be able to perform current measurements in the presence of high common-mode voltage ($>1000V_{RMS}$). This capability allows investigation and quantification of display and wiring induced losses, regardless of their origins in the lamp drive circuitry.

Current Probe Circuitry

Figure 1's circuitry meets the discussed requirements. It signals conditions a commercially available "clip-on" current probe with a precision amplifier to provide 1% measurement accuracy to 10MHz. The "clip-on" probe provides convenience, even in the presence of the high

common voltages noted. The current probe biases A1, operating at a gain of about 3.75. No impedance matching is required due to the probe's low output impedance termination. Additional amplifiers provide distributed gain, maintaining wide bandwidth with an overall gain of about 200. The individual amplifiers avoid any possible crosstalk-based error that could be introduced by a monolithic quad amplifier. D1 and Rx are selected for polarity and value to trim overall amplifier offset. The 100Ω trimmer sets gain, fixing the scale factor. The output drives a thermally-based, wideband RMS voltmeter. In practice, the circuit is built into a 2.25" × 1" × 1" enclosure which is *directly* connected, via BNC hardware, to the voltmeter. No cable is used. The result is a "clip-on" current probe with 1% accuracy over a 20kHz to 10MHz bandwidth. Figure 2 shows response for the probe-amplifier as measured on a Hewlett-Packard HP-4195A network analyzer.

LT, LTC and LT are registered trademarks of Linear Technology Corporation.

¹ Williams, Jim, "Techniques for 92% Efficient LCD Illumination." Linear Technology Corporation AN55, August 1993.

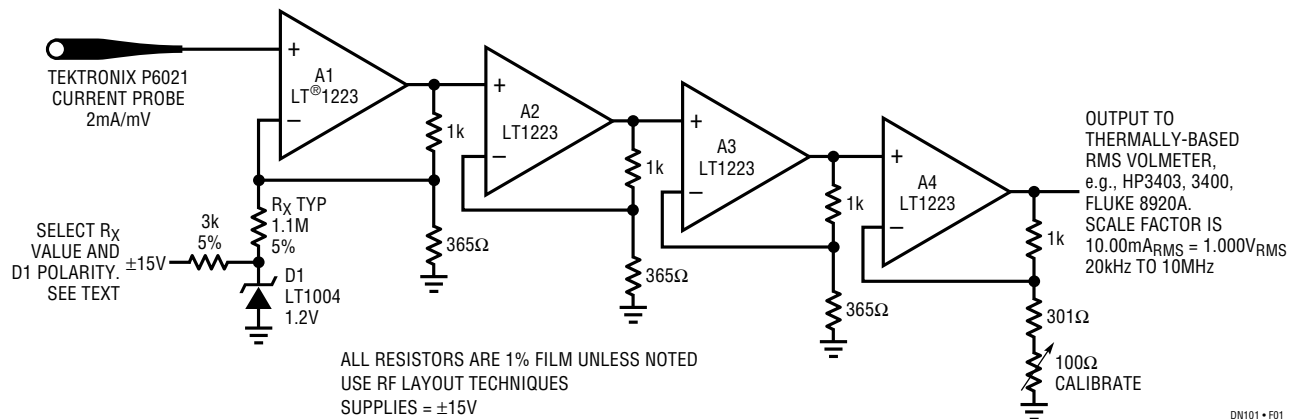

Figure 1. Precision "Clip-On" Current Probe for CCFL Measurements Maintains 1% Accuracy Over 20kHz to 10MHz Bandwidth

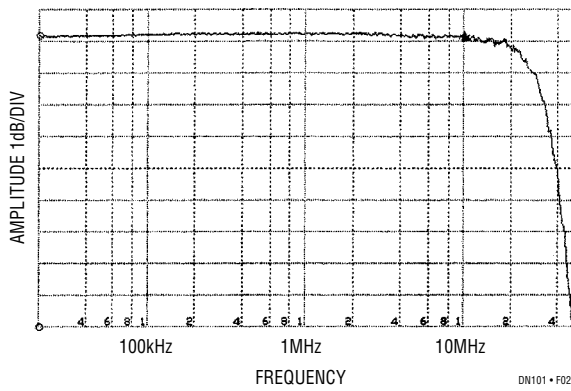

Figure 2. Amplitude vs Frequency Output of HP4195A Network Analyzer. Current Probe-Amplifier Maintains 1% (0.1dB) Error Bandwidth from 20kHz to 10MHz. Small Aberrations Between 10MHz and 20MHz Are Test Fixture Related

Current Calibrator

Figure 3's circuit, a current calibrator, permits calibration of the probe-amplifier and can be used to periodically check probe accuracy. A1 and A2 form a Wein bridge oscillator. Oscillator output is rectified by A4 and A5 and compared to a DC reference at A3. A3's output controls Q1, closing an amplitude stabilization loop. The stabilized amplitude is terminated into a 100Ω, 0.1% resistor to provide a precise 10.00mA, 60kHz current through the series current loop. Trimming is performed by altering the nominal 15k resistor for exactly 1.000V_{RMS} across the 100Ω unit.

In use, this current probe has shown 0.2% baseline stability with 1% absolute accuracy over one year's time. The sole maintenance requirement for preserving accuracy is to keep the current probe jaws clean and avoid rough or abrupt handling of the probe².

² Private Communication. Tektronix, Inc.

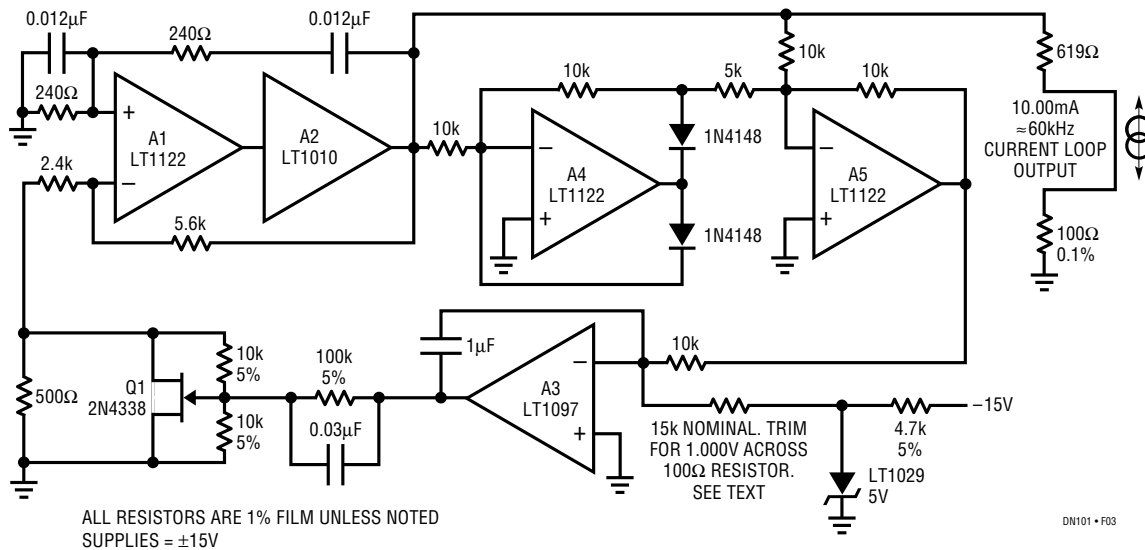

Figure 3. Current Calibrator for Probe Trimming and Accuracy Checks. Stabilized Oscillator Forces 10.00mA Through Output Current Loop at 60kHz

For literature on our High Speed Amplifiers, call **1-800-4-LINEAR**. For applications help, call (408) 432-1900, Ext. 456